

Vehicle Type	FORD TRANSIT, MERCEDES SPRINTER, VOLKSWAGEN, KIA BONGO, OPEL, FIAT BOXER
Gearbox Type	Horizontal Split Shaft PTO

Product Code	UARA.210.2.H
---------------------	---------------------

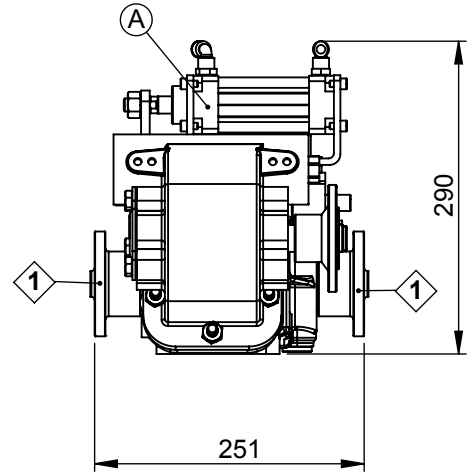

Products Views

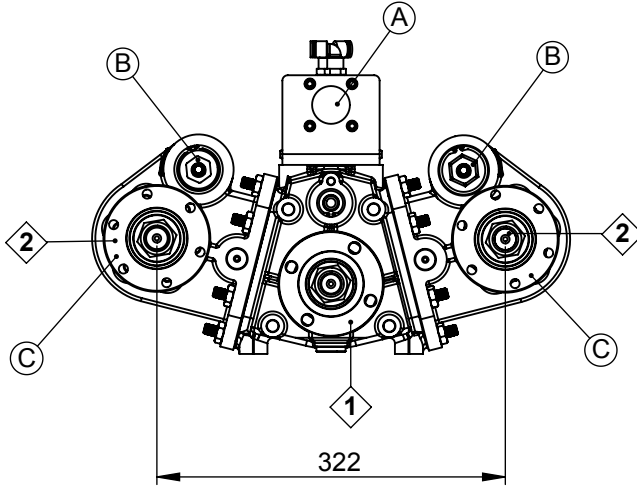
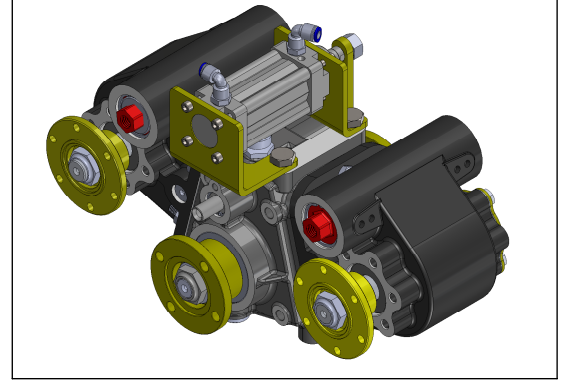
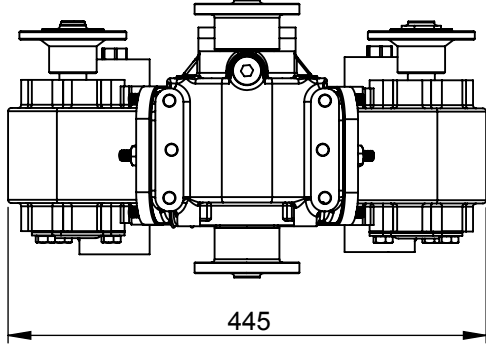

Component Details

A: Ara Şanzıman Kontrol (Havalı)
B: P.T.Ö. Kontrol (Havalı)
C: DIN 5463 (6x21x25)

A: Split Shaft Unit Control (Pneumatic)
B: PTO'S Control (Pneumatic)
C: DIN 5463 (6x21x25)

Technical Details

Outputs	Max. Power	Max. Torque		Internal Ratio	Mounting Side	Control Type
	@1000 rpm	Nm	kgm			
1		2060	210	1/1	Split Shaft	Pneumatic
2	37	353	36	1/1.42		
3					36 kg	Same as Input